

/// PCR - MCR

EN

MINI CRANES SERIES



ELDA BY **PLATFORM**
BASKET

MADE IN ITALY

/// MINI CRANES / SERIES

ELMA mini crawler cranes offer superb performance in goods movement and transport, while being light and compact enough to operate in small spaces and on uneven surfaces.

They can be used either as stabilised cranes (e.g. the MCR) or for pick & carry (PCR and MCR).



Easy to transport:

all models can be transported with a light trailer (3.5T).

Applications: ideal for maintenance and construction operations either indoors or outdoors, such as the movement of building materials or support on the site.

Lightweight structure: the operational weight is moderate, and therefore particularly suitable on delicate surfaces or where there are attics or balconies.

/// PCR10

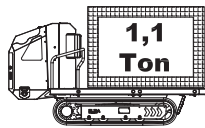

The PCR10 is a crawler vehicle without stabilisers and with a platform load capacity of 1.1T.



Motorised: the entire range is available with propulsion by endothermic petrol engine for outdoor use, or in a hybrid version with the addition of a single-phase 220 Vac electric motor for use inside and outside buildings.

Alternatively, and in line with rigorous environmental criteria, the range can be fitted with lithium ion batteries and a charging system using network power, enabling their use with no emissions or noise and making this a highly sustainable solution.

/// PCR12

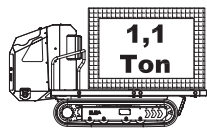

The PCR12 is a crawler vehicle without stabilisers and with a platform load capacity of 1.1T and a crane of 1.2Tm, plus the option of a winch or other features such as a glass installation system.

/// MCR30

The MCR30 is a crawler vehicle with adjustable position stabilisers and 3Tm crane performance rating. Can be fitted with a winch or other features such as a glass installation system.



Can also be used without stabilisers, as a pick & carry crane.



/// MCR40

The MCR40 is a crawler vehicle with adjustable position stabilisers and 4Tm crane performance rating.

Can be fitted with a winch or other features such as a glass installation system.
Can also be used without stabilisers, as a pick & carry crane.



1

4.0 telematic service for remote diagnostics.

These products are fitted with devices for the diagnosis and management of data from the on-board electronic control panel.



2

Quiet operation is assured in the petrol version, in compliance with relevant legislation, or in the full-electric version, for the total elimination of noise emissions.



3

The entire range is available in the **FULL-RADIO** version for safer and more efficient use.

The same radio command handles the crane, the winch, other equipment, movement and, where present, stabilisers.



PCR10 / MINI CRANES SERIES

The crawler platform without stabilisers and with a load capacity of 1.1T

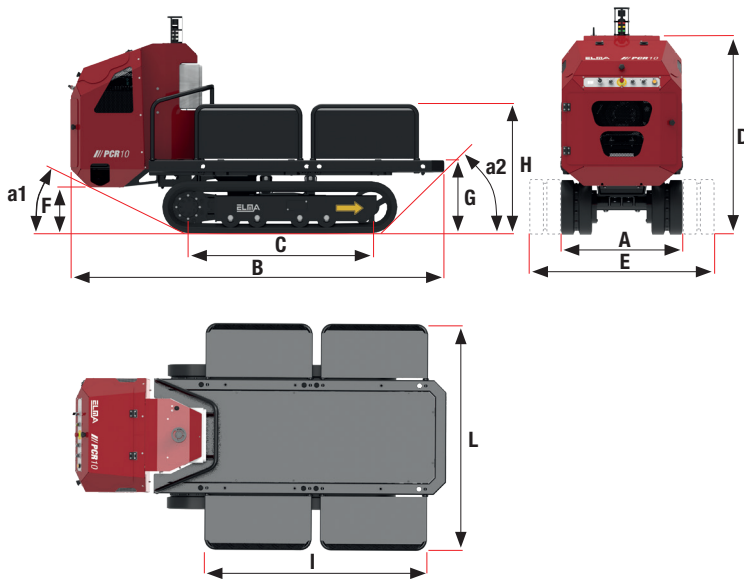

TECHNICAL SPECIFICATIONS		STD	E
A	m	0,70	
B	m	2,52	
C	m	1,24	
D	m	1,3	
E	m	1,18	
F	m	0,33	
G	m	0,47	
H	m	0,85	
I	m	1,51	
L	m	1,54	
a1	°	31°	
a2	°	39°	
Maximum platform load	kg	1100	
Maximum speed of movement	km/h	2,6	
Maximum slope capacity	°	25°	
WEIGHTS		ST	E
Standard machine weight	kg	1000	1050
Track ground pressure	kg/cm ²	0,12	0,13
FUEL		ST	E
PETROL ENGINE	8,7kW/11,7HP @3600 rpm	•	-
230 Vac ELECTRIC MOTOR (OPTIONAL)	2,2kW/3HP 230Vac/50Hz	•	-
ELECTRIC TRACT. MOTOR	3,5kW/5HP 48Vdc	-	•
BATTERY TYPE	48Vdc 110Ah Lithium Ion	-	•

OPTIONAL:

- White tracks
- 230 Vac electric pump
- Adjustable tracks
- Radio control



PCR12 / MINI CRANES SERIES



The crawler mini crane without stabilisers and with a platform load capacity of 1.1T

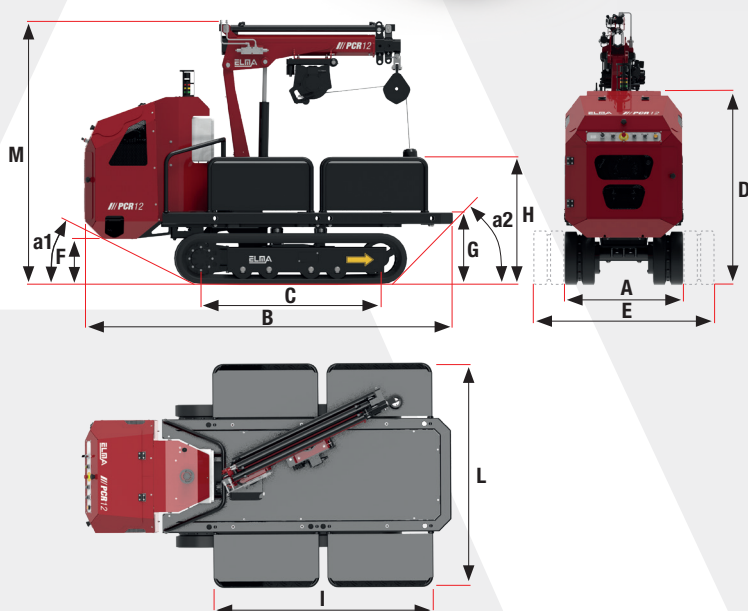

TECHNICAL SPECIFICATIONS		STD	E
A	m	0,79	
B	m	2,52	
C	m	1,24	
D	m	1,3	
E	m	1,18	
F	m	0,33	
G	m	0,47	
H	m	0,85	
I	m	1,51	
L	m	1,54	
M	m	1,68	
N	m	2,7	
a1	°	31°	
a2	°	39°	
b	°	25°	
Crane maximum moment	Tm	1,2	
Maximum horizontal working radius	m	3,41	
Maximum movable load	kg	990	
Crane arm working angle	°	+70° -30°	
Crane rotation angle	°	340°	
Rotation torque	kNm	2,5	
Maximum speed of movement	km/h	2,6	
Maximum slope capacity	°	25°	
Maximum operational pressure	bar	190	
Maximum capacity crane distributor	l/min	8	
Oil reservoir capacity	l	22	
Single winch reach (optional)	kg cable	600	
		Ø7mm - 46m	
WEIGHTS		ST	E
Standard machine weight	kg	1200	1240
Track ground pressure	kg/cm ²	0,12	0,13
FUEL		ST	E
PETROL ENGINE	8,7kW/11,7HP @3600 rpm	•	-
230 Vac ELECTRIC MOTOR (OPTIONAL)	2,2kW/3HP 230Vac/50Hz	•	-
ELECTRIC TRACT. MOTOR	3,5kW/5HP 48Vdc	-	•
ELECTRIC CRANE MOTOR	2,5kW/3,5HP 48Vdc	-	•
BATTERY TYPE	48Vdc 110Ah Lithium Ion	-	•

Diagram of operation

OPTIONAL:

- White tracks
- 230 Vac electric pump
- Single winch reach 600 kg
- Electronic kit for control of rotation angle
- Working headlamps
- Adjustable tracks
- Radio control

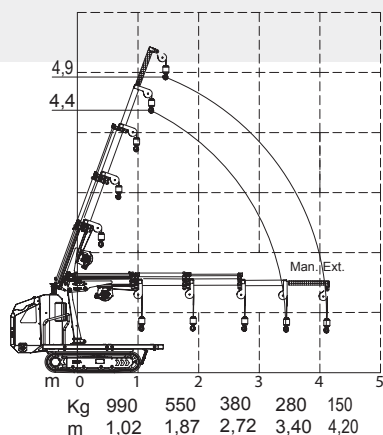

MCR30

MINI CRANES SERIES

The crawler mini crane with adjustable position stabilisers and 3Tm crane performance rating

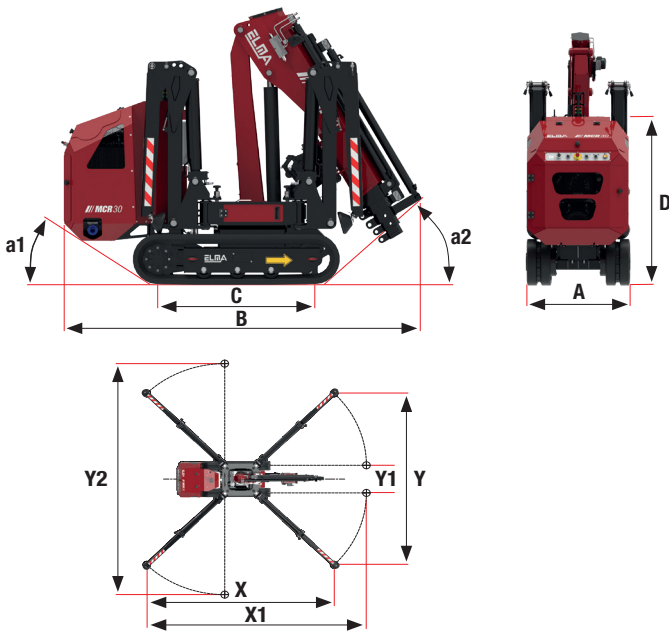

TECHNICAL SPECIFICATIONS		STD	E
A	m	0,79	
B	m	2,22	
C	m	1,09	
D	m	1,25	
H	m	1,87	
a1	°	33°	
a2	°	40°	
X	m	3,88	
Y	m	3,85	
X1	m	4,55	
Y1	m	0,62	
Y2	m	5,19	
Crane maximum moment	Tm	3,2	
Maximum horizontal working radius	m	4,75	
Maximum movable load	kg	995	
Crane arm working angle	°	± 80°	
Crane rotation angle	°	340°	
Rotation torque	kNm	3,2	
Maximum speed of movement	km/h	2,6	
Maximum slope capacity	°	25°	
Maximum operational pressure	bar	190	
Maximum capacity crane distributor	l/min	8	
Oil reservoir capacity	l	22	
Single winch reach (optional)	kg cable	600	
		Ø7mm - 46m	
WEIGHTS		ST	E
Standard machine weight	kg	1400	1440
Track ground pressure	kg/cm ²	0,25	0,26
Maximum load on stabiliser foot	kg	1160	
FUEL		ST	E
PETROL ENGINE	8,7kW/11,7HP @3600 rpm	•	-
230 Vac ELECTRIC MOTOR (OPTIONAL)	2,2kW/3HP 230Vac/50Hz	•	-
ELECTRIC TRACT. MOTOR	3,5kW/5HP 48Vdc	-	•
ELECTRIC CRANE MOTOR	2,5kW/3,5HP 48Vdc	-	•
BATTERY TYPE	48Vdc 110Ah Lithium Ion	-	•

Diagram of operation

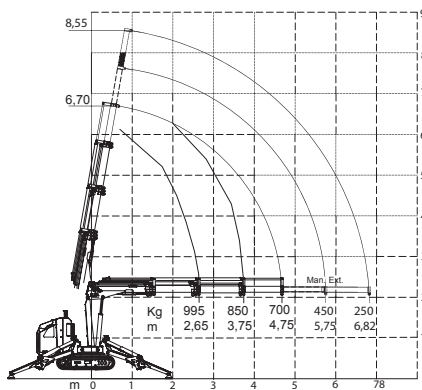

OPTIONAL:

- Adjustable tracks
- White tracks
- 230 Vac electric pump
- Single winch reach 600 kg
- Working headlamps
- Radio control
- Glass installation system

MCR40

MINI CRANES SERIES



The crawler mini crane with adjustable position stabilisers and 4Tm crane performance rating

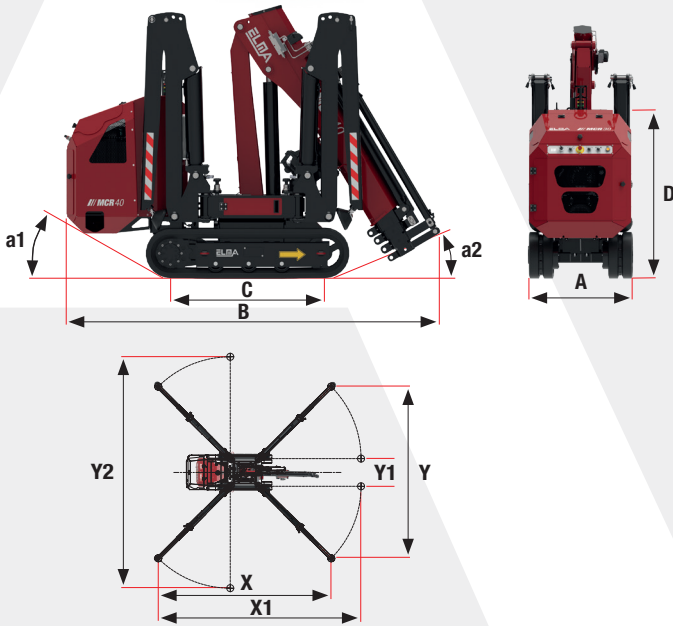

TECHNICAL SPECIFICATIONS		STD	E
A	m	0,79	
B	m	2,54	
C	m	1,09	
D	m	1,25	
H	m	1,93	
a1	°	25°	
a2	°	-	
X	m	4,7	
Y	m	4,66	
X1	m	5,55	
Y1	m	0,62	
Y2	m	6,33	
Crane maximum moment	Tm	4,0	
Maximum horizontal working radius	m	6,1	
Maximum movable load	kg	2100	
Crane arm working angle	°	± 80	
Crane rotation angle	°	340°	
Rotation torque	kNm	3,2	
Maximum speed of movement	km/h	2,5	
Maximum slope capacity	°	25°	
Maximum operational pressure	bar	200	
Maximum capacity crane distributor	l/min	8	
Oil reservoir capacity	l	22	
Single winch reach (optional)	kg cable	800	
		Ø7mm - 46m	
WEIGHTS		ST	E
Standard machine weight	kg	1460	1500
Track ground pressure	kg/cm ²	0,37	0,38
Maximum load on stabiliser foot	kg	1700	
FUEL		ST	E
PETROL ENGINE	8,7kW/11,7HP @3600 rpm	•	-
230 Vac ELECTRIC MOTOR (OPTIONAL)	2,2kW/3HP 230Vac/50Hz	•	-
ELECTRIC TRACT. MOTOR	3,5kW/5HP 48Vdc	-	•
ELECTRIC CRANE MOTOR	2,5kW/3,5HP 48Vdc	-	•
BATTERY TYPE	48Vdc 110Ah Lithium Ion	-	•

Diagram of operation

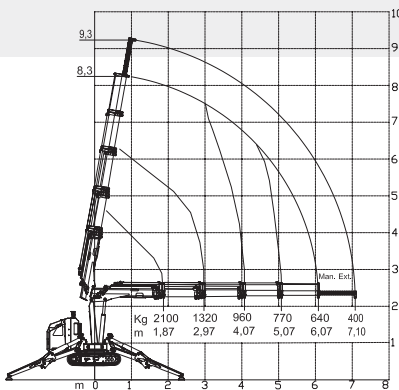

OPTIONAL:

- Adjustable tracks
- White tracks
- 230 Vac electric pump
- Single winch reach 800 kg
- Electronic kit for control of rotation angle
- Stabiliser position control kit 90°
- Working headlamps
- Radio control
- Glass installation system



ELMA SRL is part of the Platform Basket group, and offers a range of machinery complementary to that of the group.



campbellsci.com | 46223 | EN | 10/2023 | The data are approximate, not binding.



ELMA S.R.L.
Via Montessori, 1 - 42028 Poggio (RE) Italy
Ph. +39 0522 967666
E-mail: info@elma-italy.com



elma-italy.com

